

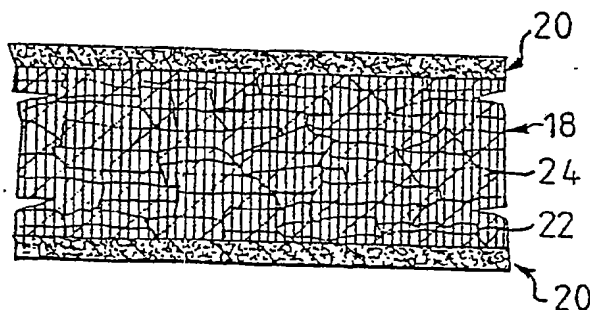

## INTERNATIONAL APPLICATION PUBLISHED UNDER THE PATENT COOPERATION TREATY (PCT)

(51) International Patent Classification 4 : B27N 3/02, B32B 21/02	A1	(11) International Publication Number: WO 89/ 08539 (43) International Publication Date: 21 September 1989 (21.09.89)
<p>(21) International Application Number: PCT/SE89/00130</p> <p>(22) International Filing Date: 13 March 1989 (13.03.89)</p> <p>(31) Priority Application Number: 8800950-1</p> <p>(32) Priority Date: 16 March 1988 (16.03.88)</p> <p>(33) Priority Country: SE</p> <p>(71) Applicant (for all designated States except US): INSTITUTET FÖR TRÄTEKNISK FORSKNING [SE/SE]; Box 5609, S-114 86 Stockholm (SE).</p> <p>(72) Inventor; and</p> <p>(75) Inventor/Applicant (for US only) : BLÜMER, Hartwig [DE/SE]; Seldonsvägen 15, S-175 39 Järfälla (SE).</p> <p>(74) Agents: HJÄRNE, Per-Urban et al.; H. Albihns Patentbyrå AB, Box 3137, S-103 62 Stockholm (SE).</p>	<p>(81) Designated States: AT (European patent), AU, BE (European patent), CH (European patent), DE (European patent), FI, FR (European patent), GB (European patent), IT (European patent), JP, LU (European patent), NL (European patent), SE (European patent), SU, US.</p> <p>Published With international search report.</p>	

(54) Title: A METHOD FOR THE MANUFACTURE OF CHIPBOARD, AND CHIPBOARD MANUFACTURED IN ACCORDANCE WITH THE METHOD



## (57) Abstract

The invention relates to a method for the manufacture of chipboard comprising a centre layer (18) of coarse chips and outer layers (20) of chips whose fibres are oriented in the plane of the board. In order to be able to reduce the density of the finished board while retaining the intrinsic characteristic profile of the board, it is proposed in accordance with the invention that the chips used to compose the centre layer (18) will comprise end-grain cut, flake-like chips (22) whose fibres are oriented in the thickness direction (24) of the chips, the chip fibres in the centre layer being oriented substantially transversely to the plane of the chipboard. The invention also relates to chipboard manufactured in accordance with the method.

*FOR THE PURPOSES OF INFORMATION ONLY*

Codes used to identify States party to the PCT on the front pages of pamphlets publishing international applications under the PCT.

AT	Austria	FR	France	ML	Mali
AU	Australia	GA	Gabon	MR	Mauritania
BB	Barbados	GB	United Kingdom	MW	Malawi
BE	Belgium	HU	Hungary	NL	Netherlands
BG	Bulgaria	IT	Italy	NO	Norway
BJ	Benin	JP	Japan	RO	Romania
BR	Brazil	KP	Democratic People's Republic of Korea	SD	Sudan
CF	Central African Republic	KR	Republic of Korea	SE	Sweden
CG	Congo	LI	Liechtenstein	SN	Senegal
CH	Switzerland	LK	Sri Lanka	SU	Soviet Union
CM	Cameroon	LU	Luxembourg	TD	Chad
DE	Germany, Federal Republic of	MC	Monaco	TG	Togo
DK	Denmark			US	United States of America

A method for the manufacture of chipboard, and chipboard manufactured in accordance with the method.

5 The present invention relates to a method for the manufacture of chipboard, or particle board, comprising a centre layer of coarse chips and outer layers of chips whose fibres are positioned in the plane of the board.

10 Conventional chipboard comprised of a centre layer of coarse wood chips and sandwiching outer layers of finer wood chips are generally characterised by a high density. This high density can be ascribed primarily to the fact that the fibres in the centre layer are positioned parallel with the longitudinal axes of the chips, i.e.  
15 in a plane which extends substantially parallel to the plane of the manufactured board, and that the chips during the compression step required to form glue joints between the chips are compressed to an appreciable extent such that the density of the board will be substantially higher than the intrinsic density of the  
20 starting material. In the case of conventional chipboard manufacture, this increase in density will reach about 50%, such as to obtain a characteristic profile which corresponds to a given chipboard standard, for instance  
25 SIS 234 801.

A high density, however, results in chipboard of lower moisture stability, primarily thickness swelling.  
Furthermore, because of its high density, chipboard is  
30 normally considered to be heavy and difficult to handle. The manufacture of conventional chipboard also involves high costs for starting materials, i.e. chips, and glue, in addition to energy costs.

5 Against the background of the afore-described known technique, there is a desire for a method by means of which the density of chipboard can be reduced, and therewith a reduction in the consumption of starting materials, while retaining the same characteristic profile in general, or while improving said profile.

10 A method which touches partially upon this problem is described in SE-B-346 945. It is stated in this document (page 10, line 27 to page 22, line 27) that the size of the chips, the direction of chip fibres and the positioning or orientation of the chips in the board influences the properties of the finished chipboard, for instance such properties as density, swelling, mechanical strength, etc. For example, it has been found that 15 when the longitudinal axes of the chip fibres are located transversely to the plane of the board, the board will be less compressible as a whole after being formed and the smaller particles located in the outer layers 20 will be compressed to a greater extent than the particles located in the core of the board. For the purpose of obtaining chipboard in which a greater percentage of fibres are located with the longitudinal axes of the fibres extending transversely to or at an angle 25 to the plane of the board, it has been proposed in accordance with SE-B-346 945 to use very short, essentially cubic chips as conventional wood chips, which because of their short lengths can be positioned with the long axes of the fibres extending both vertically and horizontally and in positions there between. There 30 is obtained in this way random orientation of fibres in all directions.

35 For the purpose of reducing density and consumption of starting materials still further, while retaining the

conventional, useful properties of the finished chip-board, or even improving the level of such properties, there is proposed in accordance with the invention a method which will impart a more refined and positive orientation of the chip fibres in the centre layer in a direction perpendicular to the plane of the finished board. To this end, it is proposed in accordance with the present invention that the chips used for the centre layer of the board are end-grain cut, flake-like chips whose fibres are oriented in the thickness direction of said chips, the chips fibres in the centre layer of the board being orientated substantially transversely to the plane of the board. By flake-shaped is meant here the shape of a body whose width and length are substantially greater than the thickness of the body. When using such flake-shaped chips, the chips will settle naturally on their respective base or top surfaces when forming the centre layer, the longitudinal axis of the fibres being oriented essentially transversely to the plane of the board. Due to the substantially unitary transverse direction of the fibres in the centre layer, a very high resistance to compression will be encountered in said layer during the compression stage, and consequently the conventional type chip particles which form the outer layers and whose fibres are orientated in the plane of the board are compressed to relatively thin layers of high density, whereas the volumetrically larger centre layer obtains a relatively low density. Tests have shown that when practicing the method proposed in accordance with the invention, there can be obtained three-ply chipboard whose total density is lower than the density of conventional chipboard, while retaining or improving the intrinsic or fundamental characteristic profile of the board. Consequently, chipboard manufactured in accordance with the novel method will require a smaller

5 quantity of wood starting materials than conventional chipboard manufactures. This lower consumption of wood starting materials also decreases costs for glue and energy in the manufacture of said board. The resultant high mass surface density of the outer layers provides denser surfaces, which, for instance, decrease paint and varnish consumption when treating the surfaces of the board and enable the board to be lined with thinner paper liners.

10 The invention also relates to chipboard, or particle board, manufactured in accordance with the method and comprising a centre layer of coarse chips and outer layers of chips whose fibres are oriented in the plane of the board, the chips in the centre layer comprising end-grain cut, flake-shaped chips whose fibres are oriented in the thickness direction of the chips, the chip fibres in the centre layer being oriented substantially transversely to the plane of the board.

20 The invention will now be described in more detail with reference to the accompanying drawings, in which Figure 1 is a schematic, longitudinal sectional view of conventional three-ply chipboard with the chip fibres extending substantially parallel to the plane of the board;

25 Figure 2 is a schematic, longitudinal sectional view of three-ply chipboard manufactured in accordance with the present invention, with the chip fibres of the centre layer oriented substantially at right angles to the plane of the board; and

30 Figure 3 is a schematic plan view of apparatus for cutting end-grain chips intended for forming the centre layer chips of chipboard constructed in accordance with the invention.

35

The conventional three-ply chipboard illustrated in Figure 1 consists of a centre layer 10 comprised of chips 12, the fibres of which are oriented in planes which extend substantially parallel with the plane of the finished board, as illustrated by lines 14. Two outer layers 16 contain finer chips, so as to provide a finer and denser surface structure subsequent to being pressed, the density of the outer layers being higher than the density of the centre layer. Board manufactured in this way will generally have a relatively high total density, resulting in heavy board, while the particular orientation of the fibres in the centre layer renders the board sensitive to moisture, which is manifested primarily in swelling of the board in the direction of its thickness. One reason for the high density of the centre layer is that the chips with fibres extending parallel to the plane of the board can be readily compressed, which means that a large quantity of wood starting material must be used in order to produce chipboard of given thickness and given acceptable fundamental characteristic profile.

The inventive chipboard, illustrated schematically in section in Figure 2, consists of a centre layer 18 and two outer layers 20. In the case of the inventive chipboard, however, the centre layer 18 is composed of end-grain cut, flake-shaped chips 22, the fibres of which are oriented in the thickness direction of the chips, as illustrated by the lines 24.

As indicated above, the invention is based on the concept of utilizing the inherent resistance to compression of the wood chips, in a manner to achieve a reduction in the density of the finished board. This presumes an

alternative method of producing the chips and of positioning the chips in the centre layer of the board. Thus, there is required a convertible starting material, such as round wood, slabs and edgings. In order to  
5 obtain a unitary chip fibre direction essentially transversely to the plane of the board when forming the centre layer, the chips need to be end-grain cut chips which are so configured that, during forming of the centre layer, the chips will position themselves  
10 such that the largest dimension of the chips will lie parallel with the plane of the board. It has been found in practice that flake-like chips or disk-shaped chips are extremely well suited for this purpose.

15 Figure 3 illustrates schematically an apparatus for producing end-grain cut chips suitable for use in the centre layer 18. Reference is made below to this apparatus in conjunction with a description of tests carried out on a laboratory scale in a comparison study  
20 between, on one hand, reference chipboard of conventional composition and manufacture, and, on the other hand, chipboard manufactured in accordance with the inventive method, this chipboard having a centre layer composed of flake-like end-grain cut chips and embraced  
25 by more dense, compressed outer layers.

#### Tests

30 An assortment of industrially produced chips were used as chip material in reference board and for the outer layers in end-grain board. The centre layer chips of the reference boards were knife cut with the fibre direction parallel with the longitudinal axis of the chips, the chips having a maximum length of about 30 mm.



The chips had an estimated maximum thickness of 2 mm. The outer chip layer comprised fine chips which fell within the fraction-composition used in the manufacture of furniture board having fine-chip outer layers.

The end-grain chips were produced from sawn, undried spruce planks measuring 65 x 155 mm.

#### Chip manufacture

In the manufacture of end-grain cut chips for the centre layer of the inventive chipboard, the planks 26 (Figure 3) were cut to a length of 90 mm measured in the fibre direction. Chip cutting was effected with the aid of a rotating disk 28 having a diameter of 815 mm and provided with 8 knives (not shown) on one end side. The disk rotated at a speed of about 900 r.p.m. The following tool angles were measured: Rake angle  $\tau = 45^\circ$ , edge angle  $\beta = 35^\circ$ , relief angle  $\alpha = 10^\circ$ . The knife setting, i.e. the distance between the flat disk and the knife edge, was selected at 1.0 mm. This setting corresponds to a nominal chip thickness of about 1.0 mm. In the manufacture of chips, the planks 26 were placed in a transport chute with the year rings of the planks facing towards the knife-carrying disk 28. The planks 26 were advanced by means of a driven press wheel 30 which urged the planks against the disk. The resultant end-grain chips thus produced were then dried and fractionated by passing the chips through a flat laboratory screen provided with square-mesh wire screen inserts. The result is set forth in Table 1 below.

Table 1. Fractional composition of the end-grain cut chips

Fraction	Screen dimensions (mm)	Percentage (%)
I	> 8.0	5.8
II	8.0 - 1.0	88.5
III	< 1.0	5.7

The fractions I and III were excluded in the subsequent board manufacturing process. Thus, solely fraction II was used. In this respect, the chips in fraction I can be made smaller and the chips in fraction III can be incorporated with the assortment of chips for producing outer layers in the industrial manufacture of chipboard.

#### Chipboard manufacture

Three-ply chipboard was manufactured at a nominal thickness of 20 mm and a density of 600 kg/m<sup>3</sup>. The centre layer constituted 60% of the thickness of the chipboard, whereas the outer layers constituted 40% of said thickness. For the purpose of studying the influence of layer density on the characteristic profile of the board, four density regions were selected for the centre and outer layers respectively.

Table 2 below discloses information concerning the nominal and measured layer density, the measured layer thicknesses in mm, the calculated layer distribution and chipboard designations. Reference chipboard was manufactured solely from conventional industrial chip assortments, and is referenced R.

5 Table 2. Nominal and measured density of surface and centre layers, and layer thicknesses.

Board No.	Nominal density		Measured density		Measured layer thickness		Distribus Surface Centre la. (%)	
	Surface layer (kg/m <sup>3</sup> )	Centre layer (kg/m <sup>3</sup> )	Surface layer (kg/m <sup>3</sup> )	Centre layer (kg/m <sup>3</sup> )	Surface layer (mm)	Centre layer (mm)		
10								
15	1	825	450	960	400	3.3	13.0	34/66
	1R	825	450	780	480	4.1	11.0	43/57
	2	750	500	960	410	2.9	13.8	30/70
	2R	750	500	790	450	4.0	11.3	41/59
20	3	675	550	980	400	2.6	14.5	27/73
	3R	675	550	780	460	3.8	11.6	40/60
	4	600	600	910	430	2.4	14.8	24/76
25	4R	600	600	810	500	2.6	14.2	27/73

30 The difference between desired nominal board density and the measured density will be clearly seen from the table.

35 It will also be seen from Table 2 that board manufactured from end-grain centre-layer chips in accordance with the invention achieves the desired surface distribution only at a low centre layer density (board 1).

All reference board manufactured from industrially used chip assortments, with the exception of board 4R, achieve the desired layer distribution 40/60.

5 The method in which the end-grain cut chips intended for the centre layer (i.e. the fibre direction) and the geometry of said chips (flake-shaped) are considered to have contributed to increased compression already in the low density regions.

10 The boards were hand-formed, sheet for sheet, in a forming box measuring 300 x 300 mm. Pressing was effected under high pressure in a hot press at a temperature of 180°C. Press plates and spacer strips were used in the pressing operation. The press closing time, i.e. the time lapse between upper press-plate contact and spacer strip contact, was very short in the case of the reference boards, more specifically an average time lapse of 10 seconds. Corresponding boards having centre layers comprising end-grain chips engendered a compression resistance which resulted in a compression time of 30-40 seconds.

25 The influence of press closing time and compression resistance on layer thickness and layer density can be seen from Table 3 below, which discloses the density factor. By density factor is meant here the ratio of the surface layer density to the centre layer density. The factor is given both for the nominal density values and for the measured values. The table also includes compression, i.e. the ratio of measured and nominal factors (increase and decrease in layer density). The table shows a marked increase in compression with increased centre layer density of board manufactured from end-grain, centre-layer chips in accordance with the inv-

30

35

5 ention. On the other hand, reference boards show a decrease (1R) and a small increase (2R and 3R) in compression. Board 4R having the highest centre-layer density also exhibits the greatest increase in compression (Table 3), which corresponds substantially to that of board 2 which has a lower centre-layer density of about 100 kg/m<sup>3</sup> (Table 2).

10 Table 3. Density factors and compression.

Board No.	Density factor		Compression	
	Nominal	Measured	Increase (+)	Decrease (-)
			(%)	
15 1	1.83	2.40	+ 31	
1R	1.83	1.63	- 11	
2	1.50	2.34	+ 56	
2R	1.50	1.76	+ 17	
20 3	1.23	2.45	+ 99	
3R	1.23	1.70	+ 38	
4	1	2.12	+ 112	
25 4R	1	1.62	+ 62	

#### Testing of inherent properties

30 The mechanical strength properties of the boards were tested in accordance with Swedish chipboard standards (SIS 234801). Four sample bodies were taken from each board, for the purpose of determining the bending strength of the board. Two test bodies were then taken from the aforesaid test bodies and tested for transversal tensile strength, each body being placed around the

35

fracture location.

5 The test carried out on the dimensional stability of the boards was restricted to investigating swelling of the boards in the direction of their thicknesses, subsequent to being submerged in water for 2 hours and 24 hours respectively. Ten test bodies from each board were included in this test. It can be mentioned that all boards had been rubbed down with an abrasive prior to 10 being tested. The prevailing density of each test body was also determined.

#### Results

15 The results obtained when testing the intrinsic properties of the board are set forth in Table 4 below. The table shows the measured characteristic properties as a mean value  $\bar{x}$  with associated standard deviations  $s$  for each individual chipboard. Within each density range 20 (combination of surface density and centre layer density) chipboard comprising end-grain centre layers was compared with reference chipboard whose centre layers comprised conventional industrial chips.

Table 4. Results obtained when determining characteristic properties - transverse tensile strength, bending strength and thickness swelling.

Board NO.	Transverse tensile strength		density (kg/m <sup>3</sup> )	Bending strength		density (kg/m <sup>3</sup> )	thickness swelling				
	$\bar{x}$ (MPa)	s (MPa)		$\bar{x}$ (MPa)	s (MPa)		$\bar{x}$ (%)	s (%)	$\bar{x}$ (%)	s (%)	density (kg/m <sup>3</sup> )
1	0,57	0,05	586	20,80	2,37	584	13,5	0,7	19,0	1,3	577
1R	0,44	0,07	603	17,71	1,55	605	17,5	0,7	20,5	1,0	605
2	0,66	0,06	583	19,69	2,40	584	13,8	0,8	19,9	1,5	581
2R	0,43	0,06	596	17,96	0,85	600	17,8	0,6	21,1	1,0	582
3	0,66	0,08	574	16,69	1,26	572	13,5	0,9	21,1	1,6	566
3R	0,49	0,05	581	16,09	1,90	588	16,6	0,4	19,8	0,6	573
4	0,71	0,06	577	16,65	2,36	579	14,8	1,7	24,9	2,3	570
4R	0,51	0,09	601	19,12	3,36	606	18,0	0,2	21,5	0,5	594

Transverse tensile strength

5 The mechanical strength of chipboard is density dependent. In the case of chipboard having a conventional  
centre layer structure, i.e. a structure in which the  
chip fibres are positioned parallel with the plane of  
the board, the density of the centre layer is a  
10 critereon of the transverse tensile strength of the  
board. Test bodies drawn from the transverse tensile  
strength test exhibit centre layer fractures, thus also  
confirming the strength influencing function of the  
centre layer. A closer study of the results obtained  
15 with the transverse tensile strength test will show that  
board whose centre layers comprise end-grain cut chips  
have a lower centre-layer density throughout in com-  
parison with corresponding reference board, irrespective  
of the board type (1-4) measured in accordance with  
Table 2. This reduction in density is calculated as  
20 being 10-20%. The reduction in centre layer density  
resulted in an increase in the outer layer density of  
end-grain cut board by 12-25%.

25 The tests showed that with a board density of 600 kg/m<sup>3</sup>,  
the end-grain boards had a transverse tensile strength  
of 0.55-0.70 MPa. Corresponding values for conventional  
reference boards were 0.45-0.50 MPa. The end-grain  
boards had these last mentioned values at densities as  
low as 525 kg/m<sup>3</sup>. Thus, the greater transverse tensile  
30 strength of end-grain board can be utilized in decreas-  
ing the board density. The extent of this reduction,  
however, is limited by the lowest permitted strength  
values.



Bending strength

Distinct from the centre-layer-density dependency of the transverse tensile strength, the bending strength of board is highly dependent on the density of the outer layers. As earlier established, the surface layer density of end-grain cut board is 12-25% higher than the surface layer density of reference board. This also implies higher strength values in the case of bending or flexural loads. In the case of end-grain cut board having a density of 600 kg/m<sup>3</sup>, the bending strength is from 18-22 MPa, depending on layer density distribution. Corresponding values for reference board (R-board) is 17-18.5 MPa. In the case of the end-grain cut board 1 and 2, these reference board values were achieved at densities as low as 550 kg/m<sup>3</sup>.

Depending on the lowest permitted bending strength values, the board density of end-grain cut boards can be made about 50 kg/m<sup>3</sup> lower than conventionally manufactured board, while still achieving the same bending strength.

Thickness swelling

The centre layer density, and therewith compression, influences the behaviour of chipboard in the presence of moisture. For instance, thickness swelling of board will increase with increased density, which as a rule has been produced by greater compression. Various methods are available for restricting swelling, at least with respect to short-term swelling (storage in water for less than 2 hours). No swelling inhibiting methods were applied during the present investigation, however. Consequently, the absolute swelling values recorded can

be understood as being very high.

Prior to carrying out the swelling tests, the moisture  
quotients of the test bodies were measured, wherewith it  
5 was found that the test bodies taken from end-grain  
board had a board moisture quotient of 4.0%. Correspond-  
ing values for the reference boards were 4.9%.

10 Table 4 shows the swelling values with associated centre  
layer density. In the case of end-grain boards 1-4,  
swelling was measured after storing the test bodies in  
water for 2 hours, and was found to be on average 13.9%.  
Corresponding average values for reference boards 1R-4R  
15 were found to be 17.5%. The difference between the  
swelling of end-grain board and reference board after  
being stored for 24 hours in water are practically non-  
existent. The higher centre layer density of the end-  
grain boards 3 and 4 engender higher swelling after 24  
20 hours than the boards 1 and 2. The relationship between  
density and swelling in the case of the reference boards  
is less distinct. With respect to swelling (2 and 24  
hours), the end-grain boards 1 and 2 offer advantages  
over the corresponding reference boards 1R and 2R.  
25 Consequently, a composition according to types 1 and 2  
should be chosen for conceivable industrial manufacture.

The afore-described tests carried out on mutually dif-  
ferent kinds of centre-layer chips illustrates that the  
characteristic profile of three-ply chipboard can be  
30 influenced by the construction of the centre layer. It  
can therewith be established that end-grain chips im-  
prove such properties as transverse tensile strength,  
bending strength and thickness swelling in a marked  
manner within a given board density range compared with  
35 conventionally manufactured chips, in which the chip

fibres are oriented in the plane of the board. This fact can be utilized to manufacture board of improved characteristic profile and/or in reducing the total board density. A reduction in board density can assist generally in achieving a reduction in costs, inter alia with respect to wood, glue, energy, transportation, etc. Low weight chipboard is desirable to the user of such board, and such low weight chipboard can be produced in accordance with the invention, as defined in the following claims.

5

10

Claims

5 1. A method for manufacturing chipboard comprising a centre layer (18) of coarse chips and surrounding outer layers (20) of chips whose fibres are oriented in the plane of the board, characterised by using as chips for the centre layer (18) end-grain cut, flake-like chips (22) whose fibres are oriented in the thickness direction (24) of the chips, the chip fibres in the centre layer (18) being oriented substantially transversely to the plane of the board.

10 2. Chipboard comprising a centre layer (18) of coarse chips and outer layers (20) of chips whose fibres are oriented in the plane of the board, characterised in that the chips (22) in the centre layer (18) consist of end-grain cut, flake-like chips whose fibres are oriented in the thickness direction (24) of the chips, the chip fibres in the centre layer (18) being oriented substantially transversely to the plane of the board.

15  
20

7/1

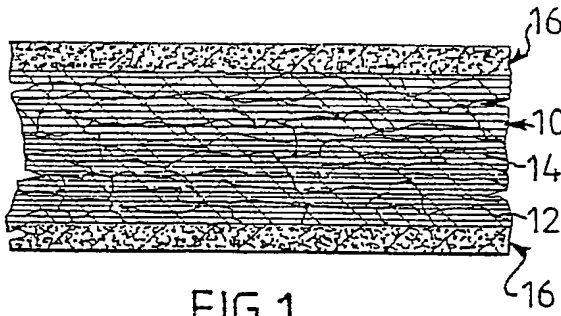

FIG. 1

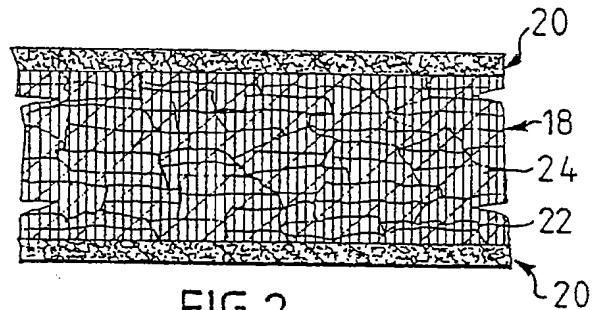

FIG. 2

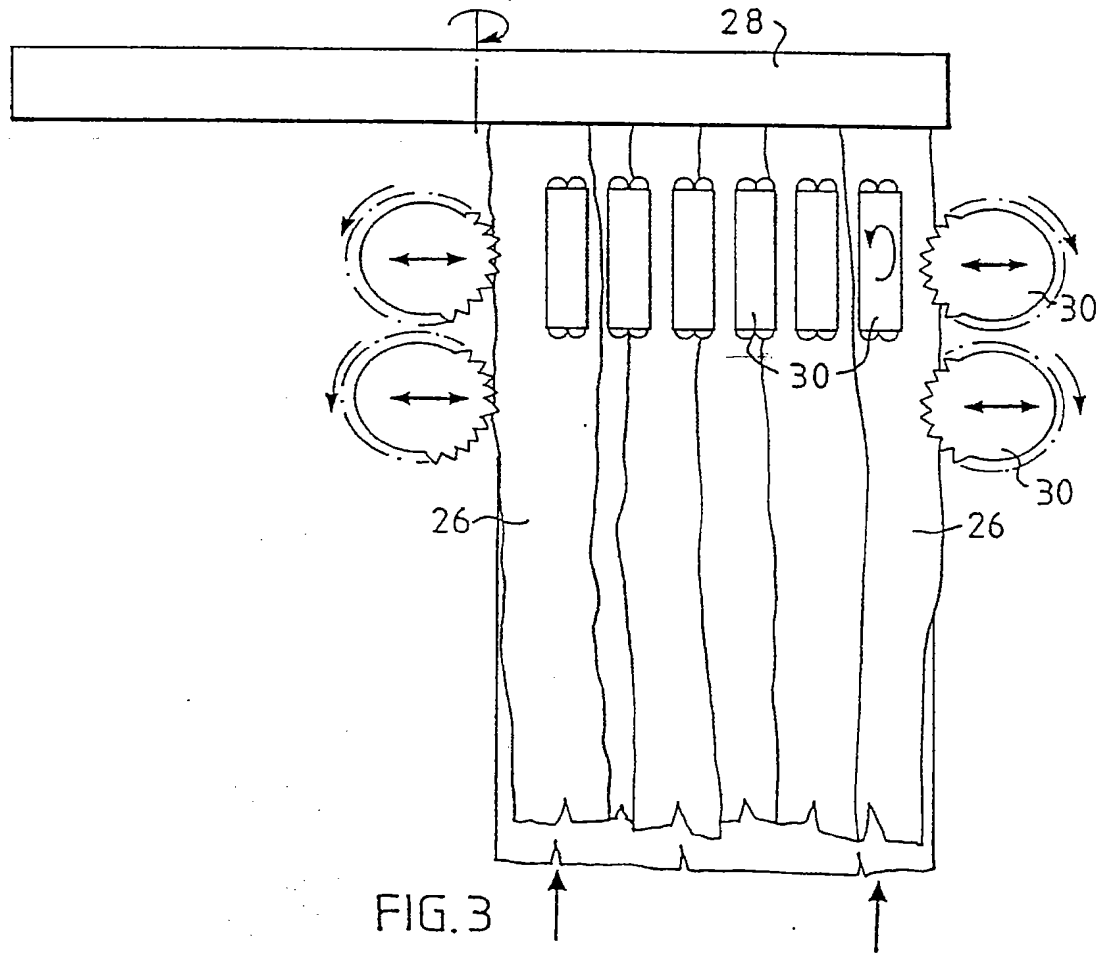
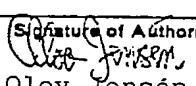

FIG. 3

# INTERNATIONAL SEARCH REPORT

International Application No PCT/SE89/00130

<b>I. CLASSIFICATION OF SUBJECT MATTER</b> (If several classification symbols apply, indicate all) <sup>6</sup> According to International Patent Classification (IPC) or to both National Classification and IPC <sup>4</sup> <p style="margin-left: 20px;">B 27 N 3/02, B 32 B 21/02</p>				
<b>II. FIELDS SEARCHED</b>				
Minimum Documentation Searched <sup>7</sup>				
Classification System <sup>1</sup>	Classification Symbols			
IPC 4	B 27 N; B 29 C; B 32 B			
US C1	<u>425</u>			
Documentation Searched other than Minimum Documentation to the Extent that such Documents are Included in the Fields Searched <sup>8</sup>				
SE, NO, DK, FI classes as above				
<b>III. DOCUMENTS CONSIDERED TO BE RELEVANT <sup>9</sup></b>				
Category <sup>10</sup>	Citation of Document, <sup>11</sup> with indication, where appropriate, of the relevant passages <sup>12</sup>	Relevant to Claim No. <sup>13</sup>		
A	SE, A, 346 945 (AB KARLSTADPLATTAN) 24 July 1972 See page 10, line 27 - page 11, line 27.	1, 2		
<table style="width: 100%; border: none;"> <tr> <td style="width: 50%; border: none; vertical-align: top;"> <sup>10</sup> Special categories of cited documents:            "A" document defining the general state of the art which is not considered to be of particular relevance            "E" earlier document but published on or after the international filing date            "L" document which may throw doubts on priority claim(s) or which is cited to establish the publication date of another citation or other special reason (as specified)            "O" document referring to an oral disclosure, use, exhibition or other means            "P" document published prior to the international filing date but later than the priority date claimed         </td> <td style="width: 50%; border: none; vertical-align: top;">           "T" later document published after the international filing date or priority date and not in conflict with the application but cited to understand the principle or theory underlying the invention            "X" document of particular relevance; the claimed invention cannot be considered novel or cannot be considered to involve an inventive step            "Y" document of particular relevance; the claimed invention cannot be considered to involve an inventive step when the document is combined with one or more other such documents, such combination being obvious to a person skilled in the art.            "Z" document member of the same patent family         </td> </tr> </table>			<sup>10</sup> Special categories of cited documents: "A" document defining the general state of the art which is not considered to be of particular relevance "E" earlier document but published on or after the international filing date "L" document which may throw doubts on priority claim(s) or which is cited to establish the publication date of another citation or other special reason (as specified) "O" document referring to an oral disclosure, use, exhibition or other means "P" document published prior to the international filing date but later than the priority date claimed	"T" later document published after the international filing date or priority date and not in conflict with the application but cited to understand the principle or theory underlying the invention "X" document of particular relevance; the claimed invention cannot be considered novel or cannot be considered to involve an inventive step "Y" document of particular relevance; the claimed invention cannot be considered to involve an inventive step when the document is combined with one or more other such documents, such combination being obvious to a person skilled in the art. "Z" document member of the same patent family
<sup>10</sup> Special categories of cited documents: "A" document defining the general state of the art which is not considered to be of particular relevance "E" earlier document but published on or after the international filing date "L" document which may throw doubts on priority claim(s) or which is cited to establish the publication date of another citation or other special reason (as specified) "O" document referring to an oral disclosure, use, exhibition or other means "P" document published prior to the international filing date but later than the priority date claimed	"T" later document published after the international filing date or priority date and not in conflict with the application but cited to understand the principle or theory underlying the invention "X" document of particular relevance; the claimed invention cannot be considered novel or cannot be considered to involve an inventive step "Y" document of particular relevance; the claimed invention cannot be considered to involve an inventive step when the document is combined with one or more other such documents, such combination being obvious to a person skilled in the art. "Z" document member of the same patent family			
<b>IV. CERTIFICATION</b>				
Date of the Actual Completion of the International Search	Date of Mailing of this International Search Report			
1989-06-07	1989 -06- 1 4			
International Searching Authority	Signature of Authorized Officer			
Swedish Patent Office	 Olov Jensen			

7/3

